

indoor air quality and energy saving

TECHNICAL DATA



EASY-P1





HRU-EC

HRU-EC is an active recovery unit for heating, cooling and air renewal of the environments (medium efficiency).

PERFORMANCE

HRU-EC can operate either as a passive recovery and as an active thermodynamic recovery and is particularly suitable for residential premises, commercial or collective residential buildings. The unit is supplied in plug-and-play version for a 'quick and simplified installation

STRUCTURE

The unit is composed of a monobloc inclusive of each component for the correct operation: fans, cooling circuit (with high efficiency INVERTER compressors and electronic expansion valve), air filtration sections and cross-flow heat exchanger (medium efficiency). The unit frame is manufactured using a profiled extruded aluminium frame and 36 mm thick sandwich panels, insulated in polyurethane foam. The panels and inner parts are manufactured in Aluzinc,[®] material that ensures high strength against corrosion and oxidation. The isolation of the panels is made with insulating that allow to have low noise and reduced transmittances during the operation of the unit. HRU-EC is equipped with electronic backward blade ventilators (compliant Erp2015). The heat exchanger is made of aluminum cross-flow with a medium efficiency (summer and winter operation) and the rotary or scroll compressor (high efficiency) has a thermal protector incorporated. Inside the unit there are two filters with filtration class M5 and F7 easily extractable. The system is managed by an electronic evolved but easy to manage.

MAIN FEATURES

ACTIVE THERMODYNAMIC RECOVERY: The unit allows the recovery of active energy of the exhaust air. The thermodynamic recovery allows, thanks to its refrigerant circuit, to provide energy to the environment in higher quantities than the energy subtracted from the ventilation.

COOLING CIRCUIT: made of copper brazed full of: high efficiency INVERTER compressor, filter drier, finned coils, solenoids, valves, electronic expansion valve, liquid receiver, pressure transducers and safety devices.

ADJUSTMENT: electric board in the unit with microprocessor and dedicated control which allows to manage:

- the temperature of the air: with room air probe (the supply-air is self-regulating to maintain the T recovery), or air delivery probe
- the fans
- the temperature probes inside the machine
- dirty filters with differential pressure sensors
- management of the defrosting algorithm optimized for operation at low temperatures
- 3-way valve 0-10 Volt for H gestioneO battery management after cooling / heating

Prepared for MODBUS RTU RS 485.

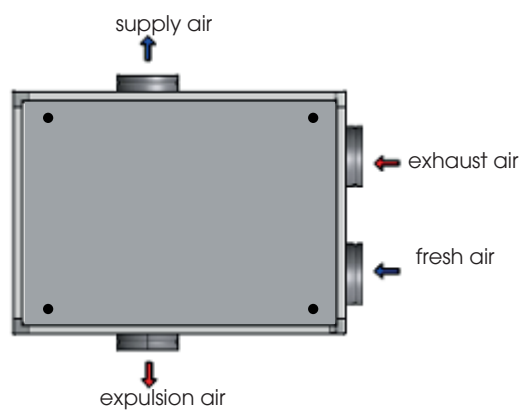
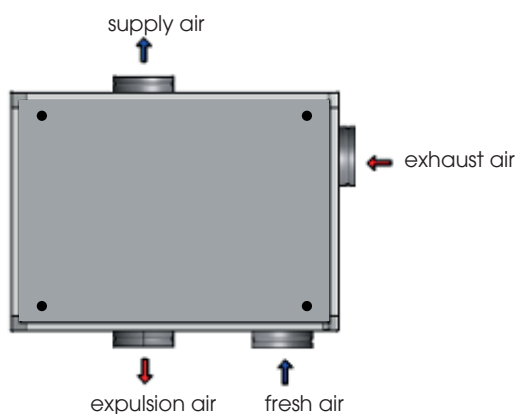
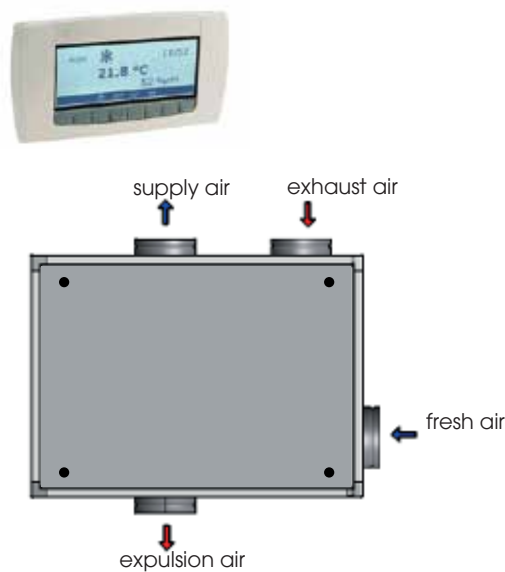
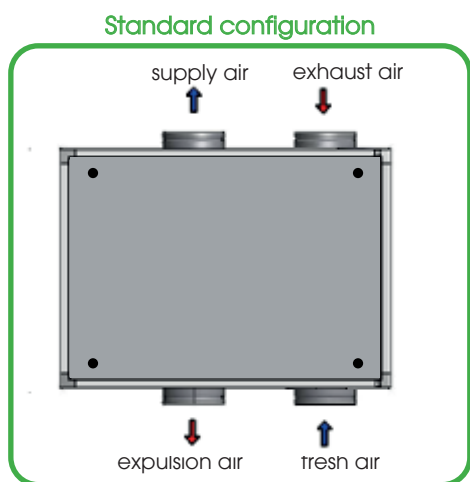

The units are views from above



Counterflow heat exchanger made of aluminum manufactured by RECUPERATOR
RECUPERATOR participates in the Eurovent Certification Program



PERFORMANCES

The unit must be ducted properly: Western authorizes the use only according to its performance diagram shown into this catalogue. The declared performances are with CLEAN filters, and guaranteed ONLY with the original filters low pressure drop.

HRU-EC 1

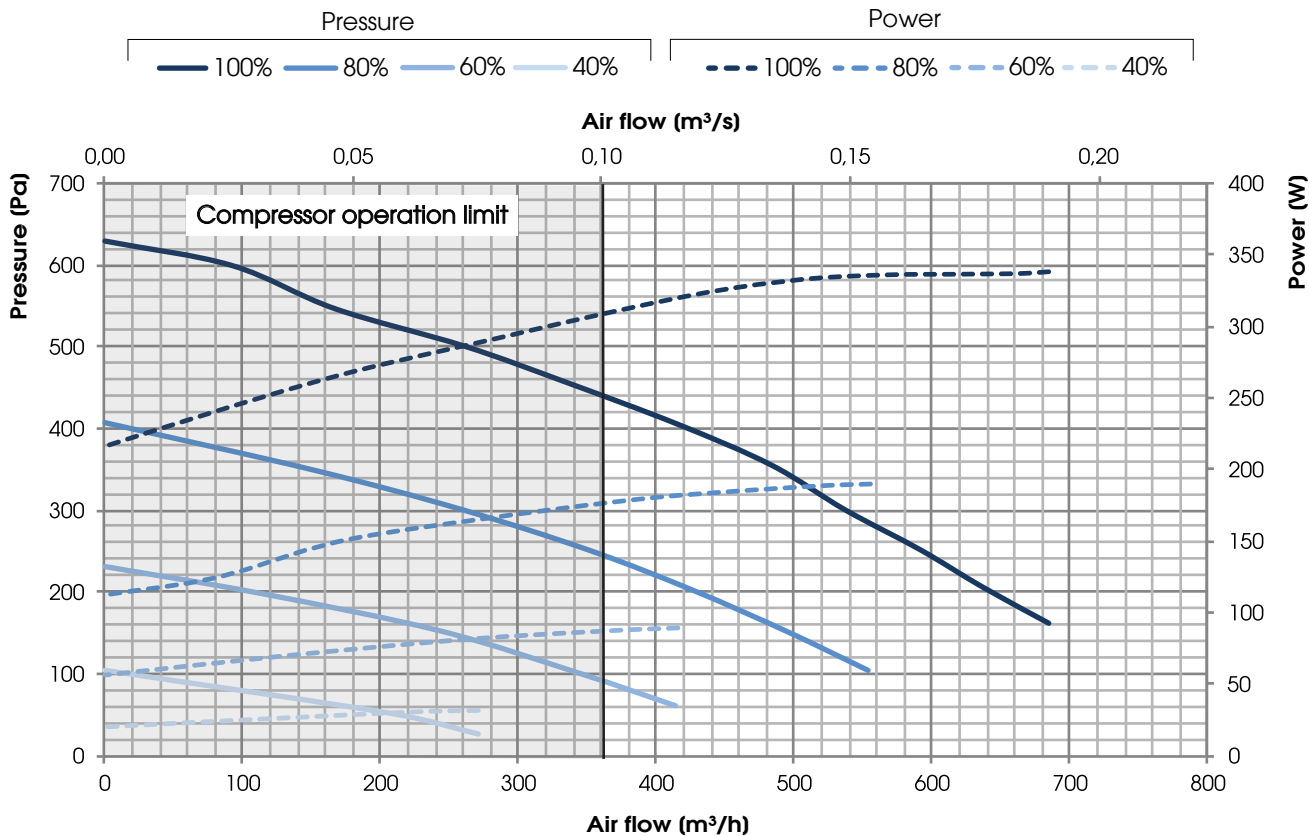

HRU-EC 2

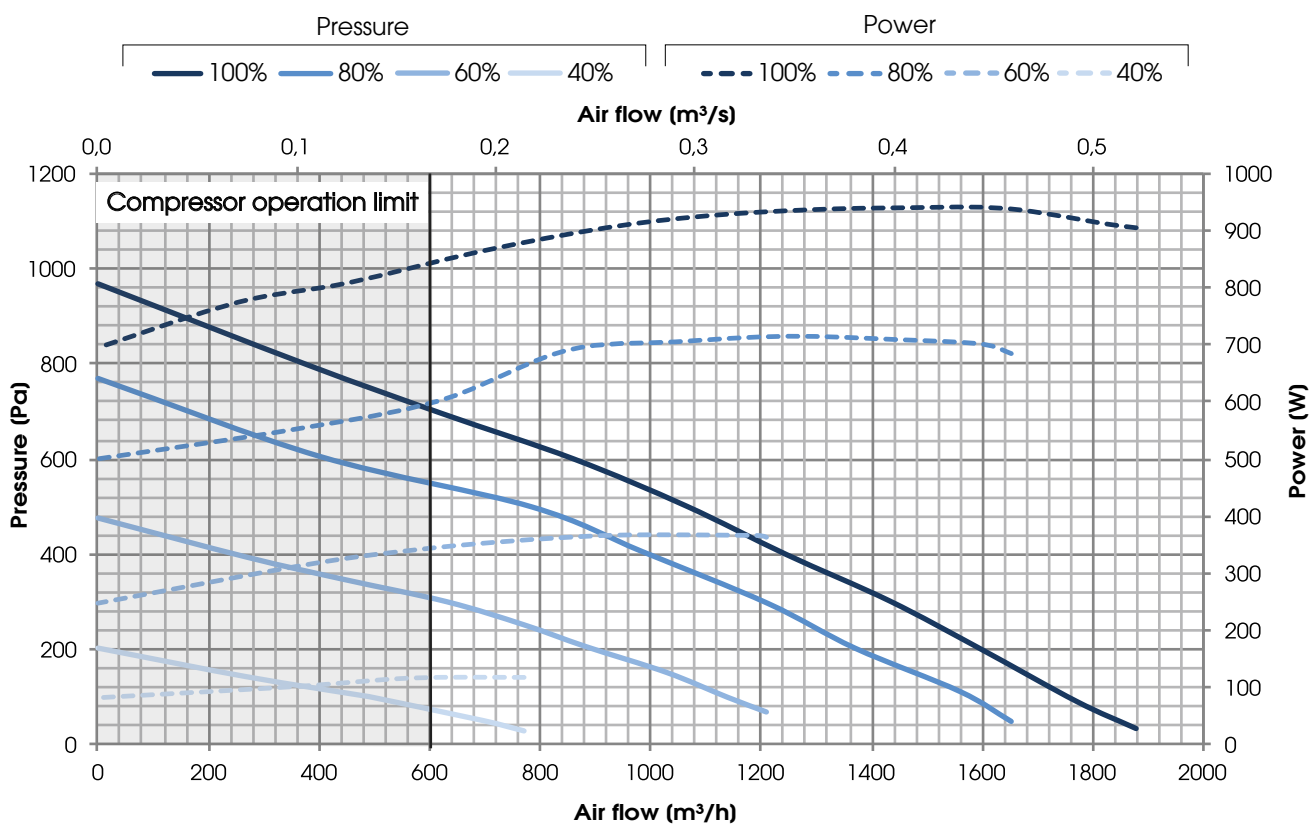



PERFORMANCES

The unit must be ducted properly: Western authorizes the use only according to its performance diagram shown into this catalogue. The declared performances are with CLEAN filters, and guaranteed ONLY with the original filters low pressure drop.

HRU-EC 3

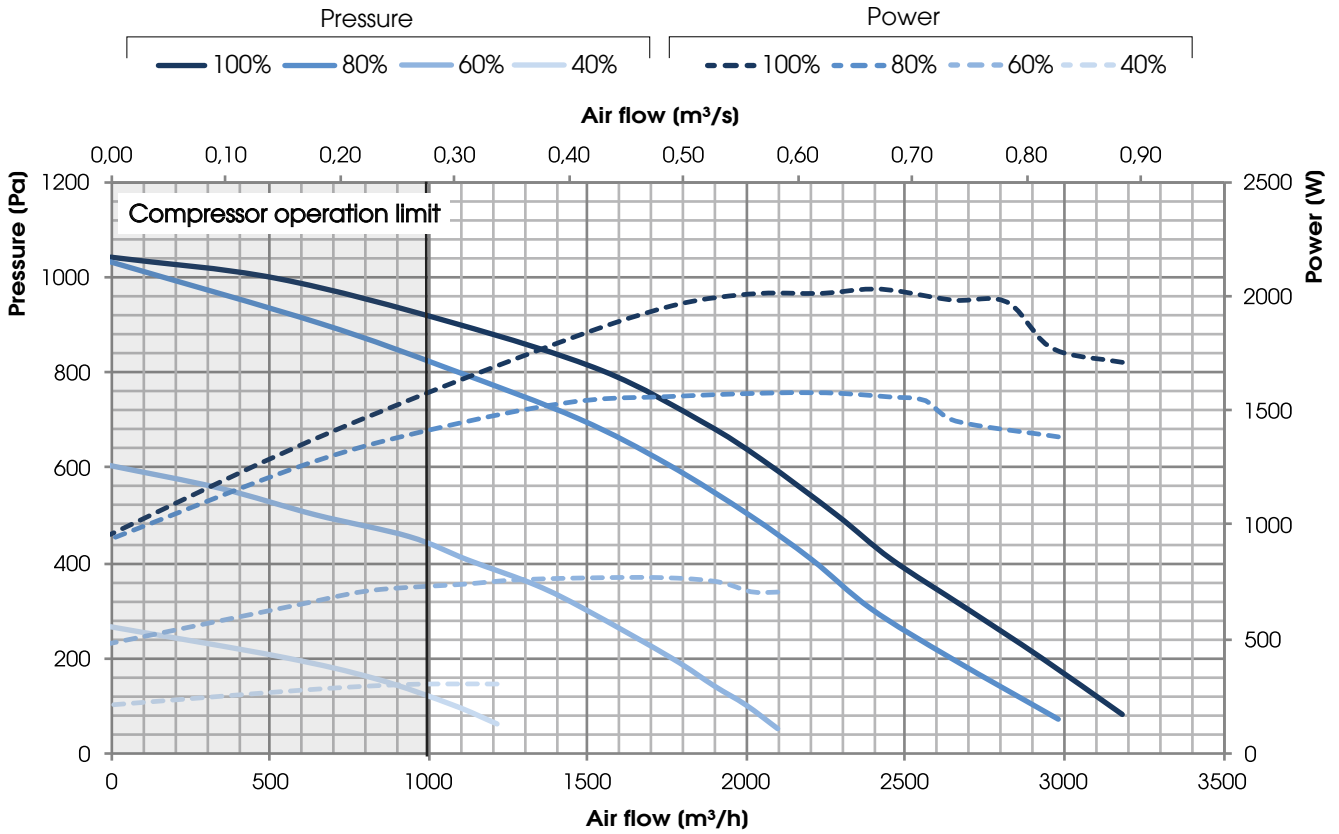

HRU-EC 4

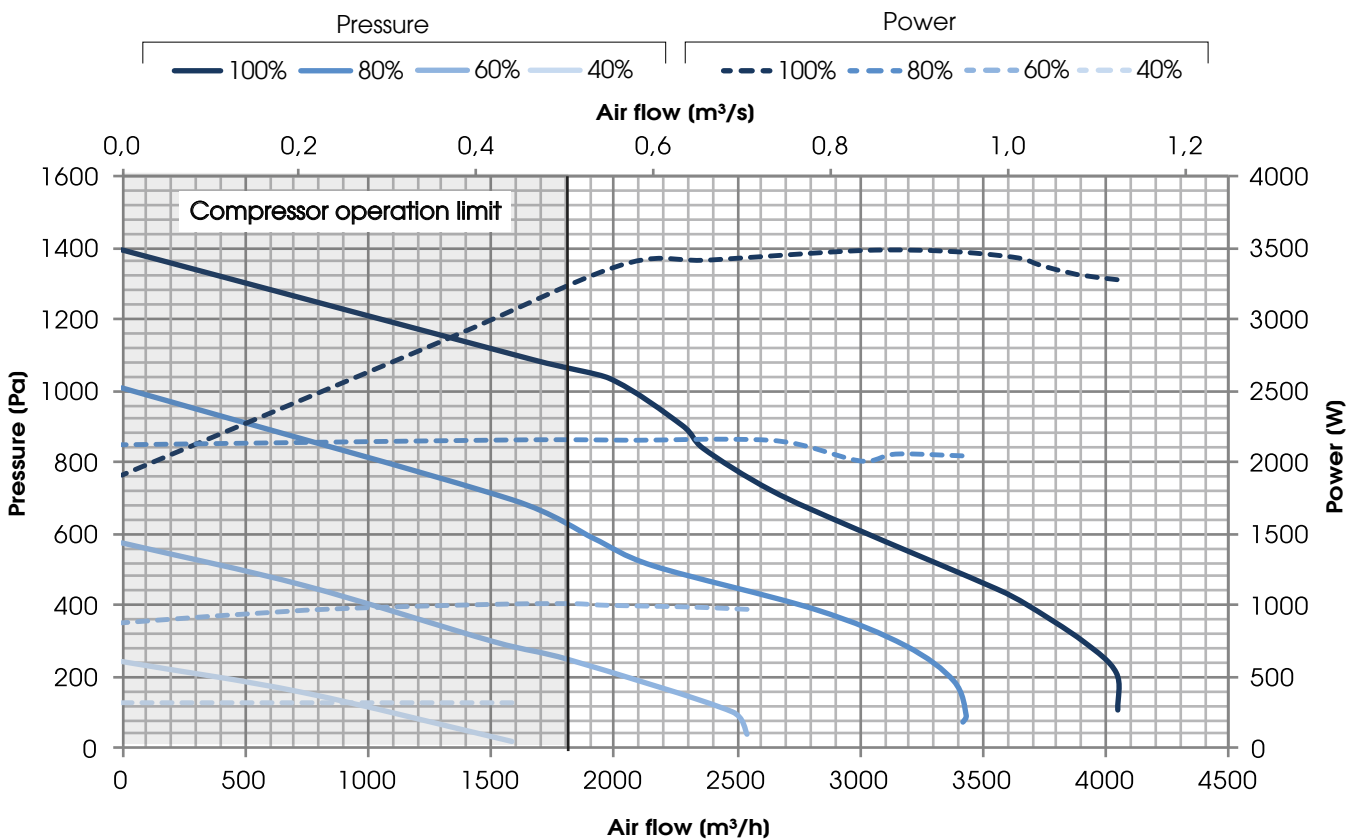



PRESTAZIONI AEREAUCICHE

L'unità deve essere canalizzata: se ne autorizza l'utilizzo solo all'interno della curva rappresentata.
Le prestazioni dichiarate sono con filtri PULITI, e garantite ESCLUSIVAMENTE con i filtri originali a bassa perdita di carico.

HRU-EC 5

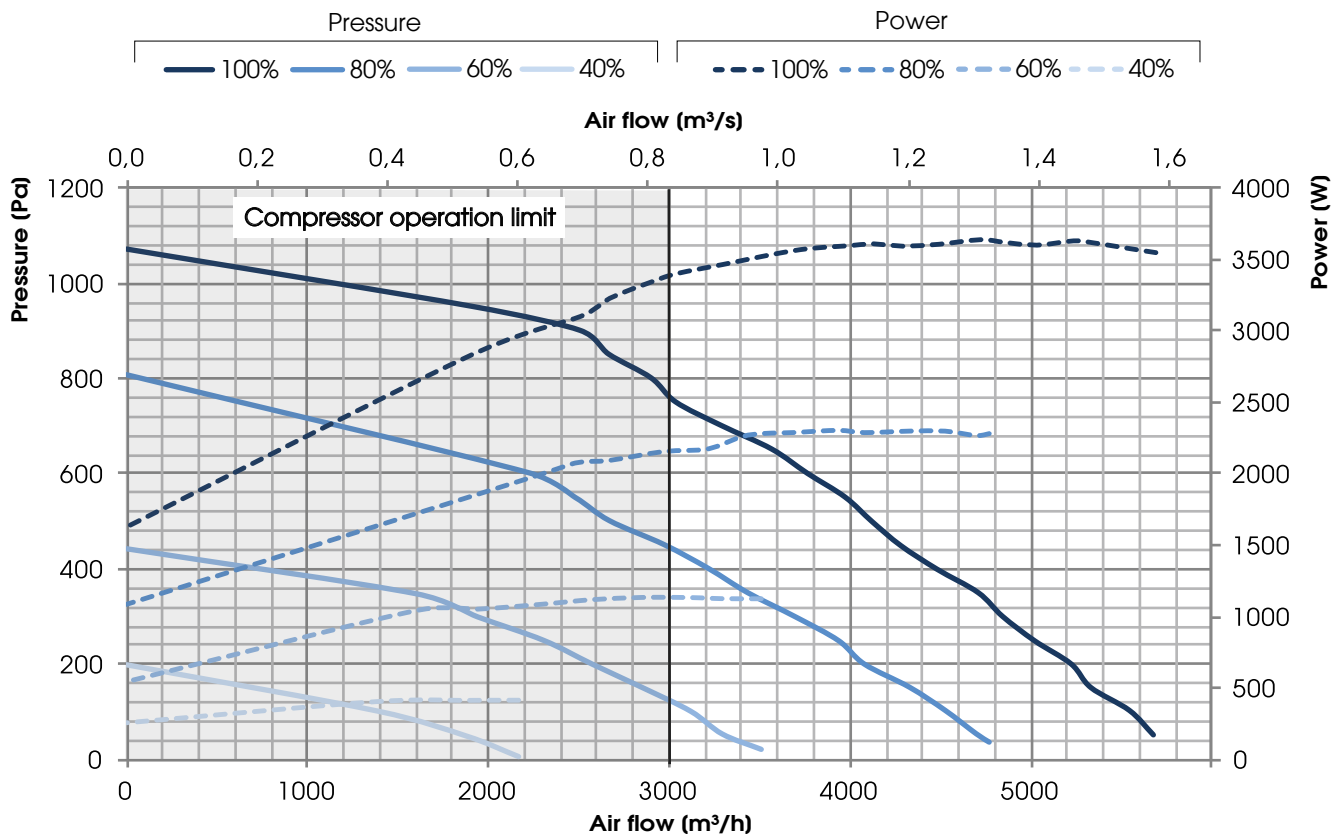

HEAT RECOVERY PERFORMANCE (sensible efficiency)

Values referred to the following conditions (UNI EN 13141-7): T_{bs} external air 5°C; U.R. external 72%; T_{bs} environment 25°C; U.R. environment 28%

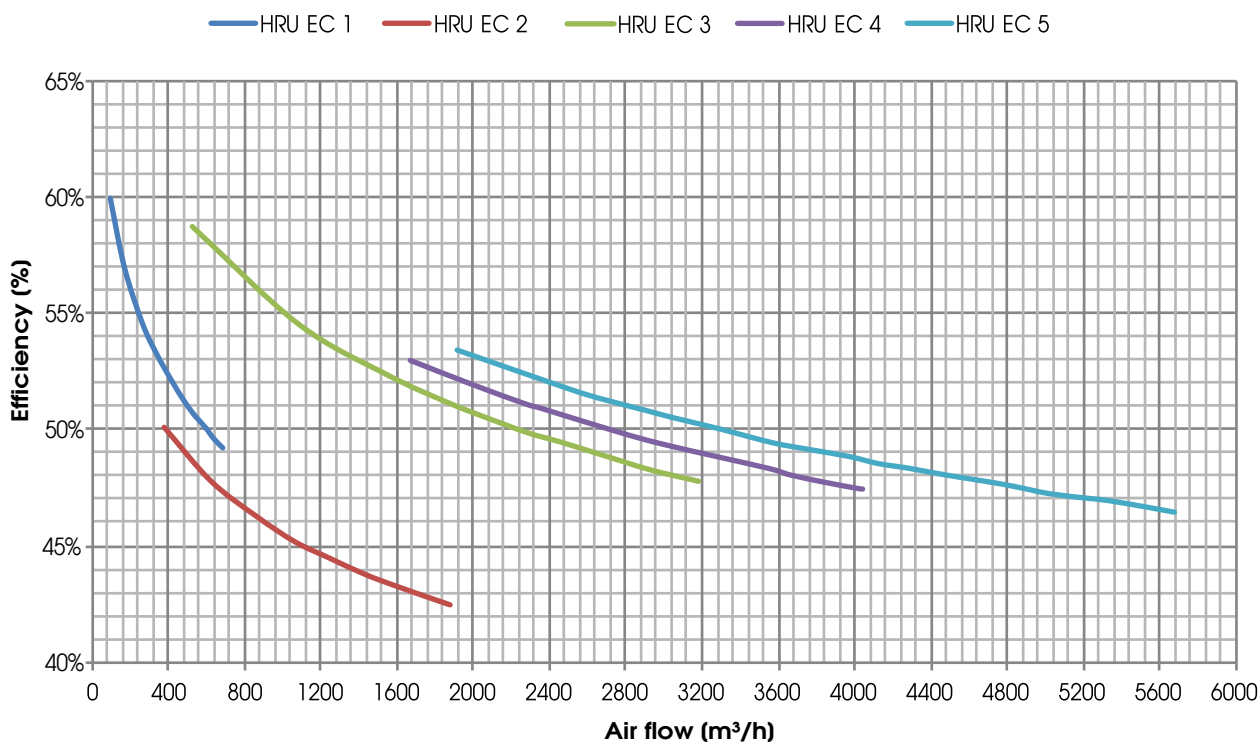



DATI TECNICI HRU-EC

TECHNICAL DATA HRU-EC 1

EXTERN	INTERN 20°C/60%					
	FREQUENCY COMPRESSOR 30 Hz			FREQUENCY COMPRESSOR 60Hz		
RECOVERY	Thermal Power	Abs. power	COP	Immission	Thermal Power	Abs. power
-5°C/ 98%	3,0 kW	0,22 kW	5,84	16,9 °C	2,55 kW	0,45 kW
7°C/ 94%	1,3 kW	0,23 kW	6,36	21,0 °C	2,90 kW	0,50 kW
15°C/ 88%	0,5 kW	0,24 kW	6,37	25,2 °C	3,04 kW	0,59 kW

EXTERN	INTERN 27°C/ 62%					
	FREQUENCY COMPRESSOR 30Hz			FREQUENCY COMPRESSOR 60Hz		
RECOVERY	Thermal Power	Abs. power	EER	Immission	Cooling power	Abs. power
25°C/ 60%	0,2 kW	1,46 kW	0,27 kW	5,25	19,3/81%	2,51 kW
35°C/ 53%	1,0 kW	1,68 kW	0,31 kW	5,33	21,8/72%	2,56 kW
38°C/ 40%	1,3 kW	1,70 kW	0,32 kW	5,23	22,5/68%	2,48 kW

EXTERN	INTERN 20°C/60%					
	FREQUENCY COMPRESSOR 30Hz			FREQUENCY COMPRESSOR 60Hz		
RECOVERY	Thermal Power	Abs. power	COP	Immission	Thermal Power	Abs. power
-5°C/ 98%	4,6 kW	3,74 kW	0,58 kW	6,44	18,3 °C	5,09 kW
7°C/ 94%	2,0 kW	4,07 kW	0,62 kW	6,51	24,7 °C	5,57 kW
15°C/ 88%	0,8 kW	4,24 kW	0,63 kW	6,73	29,7 °C	5,82 kW

TECHNICAL DATA HRU-EC 2

EXTERN	INTERN 20°C/60%					
	FREQUENCY COMPRESSOR 30Hz			FREQUENCY COMPRESSOR 60Hz		
RECOVERY	Thermal Power	Abs. power	COP	Immission	Thermal Power	Abs. power
-5°C/ 98%	4,6 kW	3,74 kW	0,58 kW	6,44	18,3 °C	5,09 kW
7°C/ 94%	2,0 kW	4,07 kW	0,62 kW	6,51	24,7 °C	5,57 kW
15°C/ 88%	0,8 kW	4,24 kW	0,63 kW	6,73	29,7 °C	5,82 kW

ESTERNO	INTERN 27°C/ 62%					
	FREQUENCY COMPRESSOR 30Hz			FREQUENCY COMPRESSOR 60Hz		
RECOVERY	Thermal Power	Abs. power	EER	Immission	Cooling power	Abs. power
25°C/ 60%	0,3 kW	3,98 kW	0,70 kW	5,66	17,2/84%	5,52 kW
35°C/ 53%	1,2 kW	4,81 kW	0,79 kW	6,05	23,5/88%	6,21 kW
38°C/ 40%	1,7 kW	4,50 kW	0,82 kW	5,46	23,6/84%	6,15 kW

EXTERN	INTERN 20°C/60%					
	FREQUENCY COMPRESSOR 30Hz			FREQUENCY COMPRESSOR 60Hz		
RECOVERY	Thermal Power	Abs. power	COP	Immission	Thermal Power	Abs. power
-5°C/ 98%	9,9 kW	5,97 kW	0,87 kW	6,86	18,2 °C	8,85 kW
7°C/ 94%	4,5 kW	6,14 kW	0,89 kW	6,87	22,8 °C	10,1 kW
15°C/ 88%	1,7 kW	6,32 kW	0,91 kW	6,94	26,9 °C	10,23 kW

TECHNICAL DATA HRU-EC 3

EXTERN	INTERN 20°C/60%					
	FREQUENCY COMPRESSOR 30Hz			FREQUENCY COMPRESSOR 60Hz		
RECOVERY	Thermal Power	Abs. power	COP	Immission	Thermal Power	Abs. power
-5°C/ 98%	9,9 kW	5,97 kW	0,87 kW	6,86	18,2 °C	8,85 kW
7°C/ 94%	4,5 kW	6,14 kW	0,89 kW	6,87	22,8 °C	10,1 kW
15°C/ 88%	1,7 kW	6,32 kW	0,91 kW	6,94	26,9 °C	10,23 kW

EXTERN	INTERN 27°C/ 62%					
	FREQUENCY COMPRESSOR 30Hz			FREQUENCY COMPRESSOR 60Hz		
RECOVERY	Thermal Power	Abs. power	EER	Immission	Cooling power	Abs. power
25°C/ 60%	0,7 kW	5,40 kW	0,92 kW	5,86	18,7/83%	9,43 kW
35°C/ 53%	2,7 kW	6,08 kW	1,01 kW	6,01	23,5/88%	10,38 kW
38°C/ 40%	3,8 kW	6,17 kW	1,08 kW	5,71	24,6/83%	10,31 kW

EXTERN	INTERN 20°C/60%					
	FREQUENCY COMPRESSOR 30Hz			FREQUENCY COMPRESSOR 60Hz		
RECOVERY	Thermal Power	Abs. power	COP	Immission	Thermal Power	Abs. power
-5°C/ 98%	9,9 kW	5,97 kW	0,87 kW	6,86	18,2 °C	8,85 kW
7°C/ 94%	4,5 kW	6,14 kW	0,89 kW	6,87	22,8 °C	10,1 kW
15°C/ 88%	1,7 kW	6,32 kW	0,91 kW	6,94	26,9 °C	10,23 kW



DATI TECNICI HRU-EC

TECHNICAL DATA HRU-EC 4

INTERN 20°C/60%													
RECOVERY		FREQUENCY COMPRESSOR 30Hz			FREQUENCY COMPRESSOR 60Hz			FREQUENCY COMPRESSOR 90Hz					
Thermal Power recovery		Thermal Power	Abs. power	COP	Immission	Thermal Power	Abs. power	COP	Immission	Thermal Power	Abs. power	COP	Immission
-5°C/ 98%	14,5 kW	10,21 kW	1,61 kW	6,34	19,4 °C	15,93 kW	3,15 kW	5,05	24,2 °C	21,62 kW	5,65 kW	3,82	30,2 °C
7°C/ 94%	6,6 kW	10,25 kW	1,55 kW	6,61	23,3 °C	17,73 kW	3,25 kW	5,45	30,3 °C	23,78 kW	6,60 kW	3,60	35,6 °C
15°C/ 88%	2,5 kW	10,27 kW	1,47 kW	6,98	27,8 °C	17,91 kW	3,31 kW	5,41	34,1 °C	25,05 kW	7,10 kW	3,52	41,5 °C
INTERN 27°C / 62%													
RECOVERY		FREQUENCY COMPRESSOR 30Hz			FREQUENCY COMPRESSOR 60Hz			FREQUENCY COMPRESSOR 90Hz					
Thermal Power recovery		Cooling power	Abs. power	EER	Immission	Cooling power	Abs. power	EER	Immission	Cooling power	Abs. power	EER	Immission
25°C/ 60%	1,0 kW	8,97 kW	1,67 kW	5,37	19,1/77%	14,5 kW	3,38 kW	4,28	17,1/79%	18,62 kW	7,05 kW	2,64	15,5/78%
35°C/ 53%	4,0 kW	10,3 kW	1,82 kW	5,65	24,8/85%	17,7 kW	4,23 kW	4,18	22,8/85%	21,40 kW	8,15 kW	2,62	21,4/84,5%
38°C/ 40%	5,5 kW	10,6 kW	1,98 kW	5,35	24,5/78%	17,2 kW	4,51 kW	3,81	22,7/78%	19,85 kW	8,61 kW	2,30	21,6/83%

TECHNICAL DATA HRU-EC 5

INTERN 20°C/60%													
RECOVERY		FREQUENCY COMPRESSOR 30Hz			FREQUENCY COMPRESSOR 60Hz			FREQUENCY COMPRESSOR 90Hz					
Thermal Power recovery		Thermal Power	Abs. power	COP	Immission	Thermal Power	Abs. power	COP	Immission	Thermal Power	Abs. power	COP	Immission
-5°C/ 98%	21,3 kW	13,61 kW	2,11 kW	6,45	18,0 °C	22,18 kW	3,98 kW	5,57	23,8 °C	32,1 kW	7,9 kW	4,06	29,4 °C
7°C/ 94%	9,7 kW	13,80 kW	2,11 kW	6,57	22,7 °C	26,91 kW	4,51 kW	5,96	29,9 °C	33,2 kW	8,3 kW	4,00	35,3 °C
15°C/ 88%	3,7 kW	15,32 kW	2,22 kW	6,90	28,0 °C	25,88 kW	5,03 kW	5,14	34,7 °C	34,9 kW	9,3 kW	3,75	39,8 °C
INTERN 27°C / 62%													
RECOVERY		FREQUENCY COMPRESSOR 30Hz			FREQUENCY COMPRESSOR 60Hz			FREQUENCY COMPRESSOR 90Hz					
Thermal Power recovery		Cooling power	Abs. power	EER	Immission	Cooling power	Abs. power	EER	Immission	Cooling power	Abs. power	EER	Immission
25°C/ 60%	1,5 kW	13,4 kW	2,40 kW	5,58	17,2/84%	23,1 kW	5,35 kW	4,31	16,8/80%	29,6 kW	9,71 kW	3,04	14,9/80%
35°C/ 53%	5,9 kW	15,9 kW	2,81 kW	5,65	24,8/86%	25,8 kW	6,28 kW	4,10	22,8/85%	32,5 kW	11,8 kW	2,75	21,5/86,0%
38°C/ 40%	8,1 kW	16,6 kW	2,98 kW	5,57	24,2/81%	25,0 kW	6,55 kW	3,81	22,7/82%	29,6 kW	11,8 kW	2,50	21,7/80%



GENERAL TECHNICAL DATA

	HRU-EC 1	HRU-EC 2	HRU-EC 3	HRU-EC 4	HRU-EC 5
Fan type	Electronic reverse blades fans				
Number of fans	2				
Nominal air flow (m ³ /h)	500	1500	2500	3500	5000
Useful pressure, renewal side (Pa)	338	569	389	464	310
Pressure useful expulsion side (Pa)	358	575	475	466	258
Compressor type	Rotary high efficiency		High-efficiency Scroll		
Refrigerant gas (R410A)	1,75	2,70	3,20	3,70	5,30
Passive heat recovery	Aluminum plates crossflow				
minimum recovery efficiency (%) (1)	55	50,5	53,7	52,6	51,3
Filters			M5/F7		
Max power absorbed fans (kW)	0,17	0,44	1,00	1,65	1,85
Max current absorbed fans (A)	1,4	2,8	1,6	2,5	2,9
Max power absorbed compressors (kW)	1,06	1,83	5,04	7,23	9,39
Max current absorbed compressors (A)	4,75	8,57	8,6	12,2	15,9
Supply voltage (V/ph/Hz)	220/1/50	220/1/50	400/3/50	400/3/50	400/3/50
Total max power absorbed (kW)	1,23	2,27	6,04	8,88	11,24
Total max current absorbed (A)	6,15	11,3	10,2	14,7	18,8
Degree of protection (IP)	20	20	20	20	20

(1) outside Air -5°C/80%UR - inside Air 20°C/50%UR - Nominal air flow

VALUES ACCORDING UNI EN 1886: 2008

MOD.	DEFORMATION CASE	LEAKAGE CASE	FILTERS CLASS	THERMAL TRANSMITTANCE	THERMAL BRIDGE
HRU-EC 1	D1 (M)	L3 (M)	F7 (M)	T4 (M)	TB3 (M)
HRU-EC 2	D1 (M)	L3 (M)	F7 (M)	T4 (M)	TB3 (M)
HRU-EC 3	D1 (M)	L3 (M)	F7 (M)	T4 (M)	TB3 (M)
HRU-EC 4	D1 (M)	L3 (M)	F7 (M)	T4 (M)	TB3 (M)
HRU-EC 5	D1 (M)	L3 (M)	F7 (M)	T4 (M)	TB3 (M)

TEST LEAKAGE (UNI EN 13141-7)

LEAKAGE	TEST CONDITIONS	LEAKAGE CLASSIFICATION				
		HRU-EC 1	HRU-EC 2	HRU-EC 3	HRU-EC 4	HRU-EC 5
EXTERN	Positive pressure 400 Pa	A2	A2	A2	A1	A1
EXTERN	Negative pressure 400 Pa	A2	A2	A2	A1	A1
INTERN	Pressure Difference 250 Pa	A3	A2	A2	A2	A2

NOISE LEVEL

L_w Sound power level taken in accordance to UNI EN ISO 3747 - CLASS 3

HRU-EC 1	Compressors	NOISE FROM THE CASE (dB)							L _w dB(A)
100%		125 Hz	250 Hz	500 Hz	1000 Hz	2000 Hz	4000 Hz	8000 Hz	
	OFF	59,1	67,0	60,0	51,0	47,7	35,2	42,0	61,5
80%	ON	59,8	68,6	58,9	50,4	47,9	35,7	42,5	62,0
	OFF	56,1	67,2	54,0	45,9	43,4	31,8	41,2	59,7
	ON	58,8	67,9	55,5	48,0	44,3	37,3	43,3	60,7

HRU-EC 2	Compressors	NOISE FROM THE CASE (dB)							L _w dB(A)
100%		125 Hz	250 Hz	500 Hz	1000 Hz	2000 Hz	4000 Hz	8000 Hz	
	OFF	66,3	73,5	65,5	52,1	49,8	41,3	44,0	67,2
80%	ON	68,6	75,7	67,0	53,0	50,2	41,7	44,6	69,1
	OFF	64,5	70,3	59,3	49,1	47,3	39,4	39,9	63,2
	ON	64,9	71,7	60,0	49,8	47,6	39,7	40,3	64,4



HRU-EC 3 Compressors		NOISE FROM THE CASE (dB)							
100%		125 Hz	250 Hz	500 Hz	1000 Hz	2000 Hz	4000 Hz	8000 Hz	L _w dB(A)
	OFF	71,3	75,3	73,7	64,5	59,1	51,5	53,6	73,1
80%	ON	71,3	75,5	74,3	65,2	59,2	51,9	53,8	73,6
	OFF	69,4	76,5	69,3	62,9	56,7	49,6	51,0	71,2
	ON	69,9	76,8	69,3	62,7	57,1	49,6	51,6	71,4
HRU-EC 4 Compressors		NOISE FROM THE CASE (dB)							
100%		125 Hz	250 Hz	500 Hz	1000 Hz	2000 Hz	4000 Hz	8000 Hz	L _w dB(A)
	OFF	79,3	79,8	71,6	64,3	60,3	50,4	51,3	74,2
80%	ON	79,9	81,3	71,8	63,8	59,7	50,4	50,6	75,0
	OFF	76,1	77,6	62,8	59,5	56,3	45,8	46,1	70,6
	ON	76,2	77,6	63,5	59,7	56,3	45,7	45,2	70,7
HRU-EC 5 Compressors		NOISE FROM THE CASE (dB)							
100%		125 Hz	250 Hz	500 Hz	1000 Hz	2000 Hz	4000 Hz	8000 Hz	L _w dB(A)
	OFF	77,3	83,0	70,5	61,7	57,0	53,6	54,5	75,7
80%	ON	73,3	84,9	67,9	57,8	52,7	49,3	49,1	76,8
	OFF	73,4	83,6	65,4	57,5	53,0	48,8	48,7	75,4
	ON	77,9	83,0	70,8	61,9	57,1	53,7	54,6	75,8
HRU-EC 1 Compressors		NOISE IN THE DUCTS (Hz)							
100%		125 Hz	250 Hz	500 Hz	1000 Hz	2000 Hz	4000 Hz	8000 Hz	L _w dB(A)
	OFF	65,5	82,0	67,8	58,2	61,4	59,0	63,3	74,8
80%	ON	66,9	83,1	67,8	57,4	62,3	58,5	63,0	75,6
	OFF	62,5	75,6	63,2	52,9	57,9	52,8	55,7	68,8
	ON	61,9	77,1	64,6	53,9	56,8	53,7	56,5	70,0
HRU-EC 2 Compressors		NOISE IN THE DUCTS (Hz)							
100%		125 Hz	250 Hz	500 Hz	1000 Hz	2000 Hz	4000 Hz	8000 Hz	L _w dB(A)
	OFF	71,3	96,4	86,8	72,3	72,3	68,8	72,4	89,5
80%	ON	73,4	97,7	87,6	72,8	72,5	69,1	72,7	90,6
	OFF	68,9	96,8	77,9	69,8	69,8	66,5	69,7	88,6
	ON	70,0	97,8	79,2	70,4	70,4	67,0	70,2	89,6
HRU-EC 3 Compressors		NOISE IN THE DUCTS (Hz)							
100%		125 Hz	250 Hz	500 Hz	1000 Hz	2000 Hz	4000 Hz	8000 Hz	L _w dB(A)
	OFF	77,6	85,6	78,0	79,2	75,5	74,1	80,3	85,2
80%	ON	78,1	85,7	78,2	79,4	75,6	74,3	80,3	85,3
	OFF	76,6	85,7	71,9	77,6	73,3	72,8	78,1	83,4
	ON	76,9	87,3	73,0	77,3	73,1	72,0	77,6	83,6
HRU-EC 4 Compressors		NOISE IN THE DUCTS (Hz)							
100%		125 Hz	250 Hz	500 Hz	1000 Hz	2000 Hz	4000 Hz	8000 Hz	L _w dB(A)
	OFF	84,1	87,6	83,9	83,5	76,6	75,2	79,1	87,7
80%	ON	84,1	87,7	82,9	84,0	77,3	76,0	79,7	88,0
	OFF	79,0	84,7	76,1	79,1	73,4	71,6	75,7	83,4
	ON	78,4	85,6	76,0	79,3	73,2	71,9	75,6	83,6
HRU-EC 5 Compressors		NOISE IN THE DUCTS (Hz)							
100%		125 Hz	250 Hz	500 Hz	1000 Hz	2000 Hz	4000 Hz	8000 Hz	L _w dB(A)
	OFF	75,9	86,7	78,9	82,0	75,2	71,5	76,2	85,5
80%	ON	77,3	87,9	78,9	82,1	75,2	71,5	75,7	85,8
	OFF	73,1	91,8	75,3	77,8	70,1	67,3	72,1	85,0
	ON	72,3	92,7	74,1	76,7	70,0	67,2	71,9	85,4



DIMENSIONS (mm) and WEIGHT (kg)

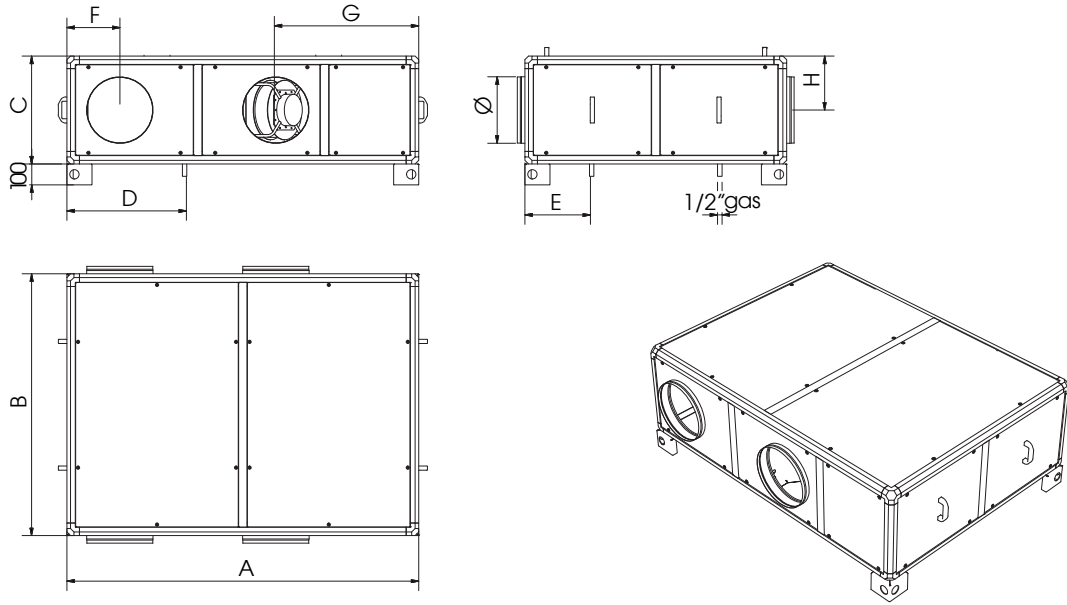

MODELL	A	B	C	Ø	D	E	F	G	H	Weight (kg)
HRU-EC 1	1400	925	415	200	495	295	245	470	208	140
HRU-EC 2	1680	1250	515	315	560	320	250	685	260	230
HRU-EC 3	1960	1430	620	355	645	390	285	615	260	325
HRU-EC 4	1960	1430	720	400	645	390	285	615	360	382
HRU-EC 5	2238	1612	922	500	722	372	335	660	461	570

HRU-EC INSTALLATION

Minimum required space for maintenance (mm)

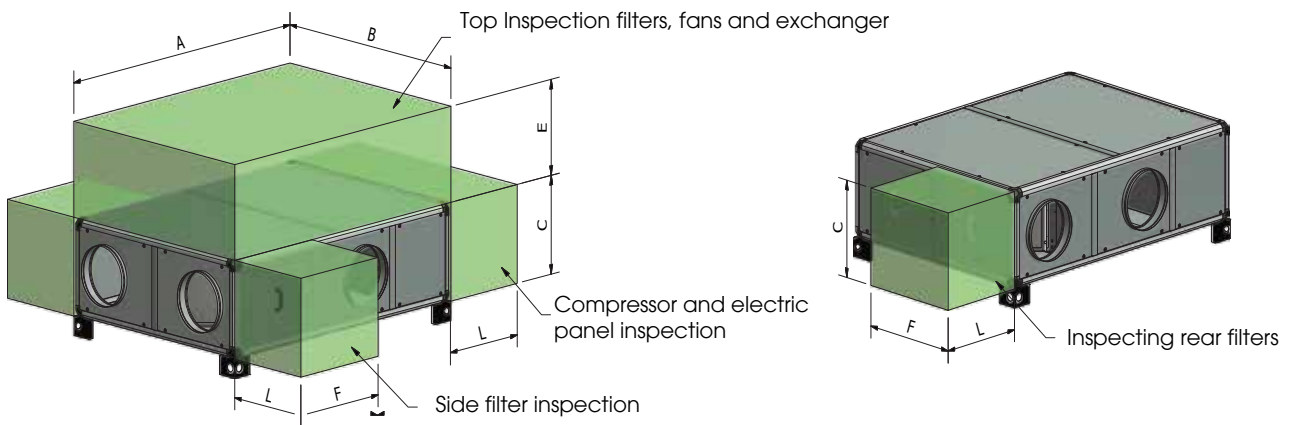

Replacing fans

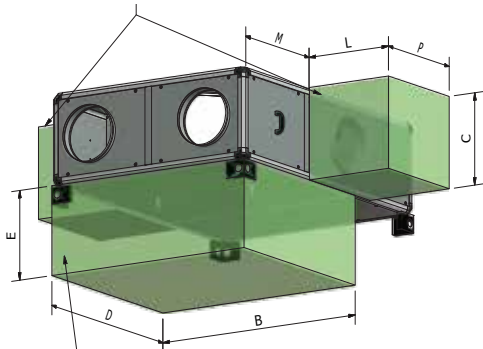

Sizes 1-2 inspection of the filters and exchanger from below
 Sizes 3-4-5 inspection of the filters from below

MODEL	A	B	C	D	E	F	L	M	P
HRU-EC 1	1400	925	415	1400	400	460	500	480	600
HRU-EC 2	1680	1250	515	1100	500	620	500	640	560
HRU-EC 3	1960	1430	620	530	600	530	500	1000	490
HRU-EC 4	1960	1430	720	530	700	530	500	1000	490
HRU-EC 5	2240	1610	920	625	500	620	500	1290	590



OPERATION LIMITS

	INTERNAL AIR				
	HRU-EC 1	HRU-EC 2	HRU-EC 3	HRU-EC 4	HRU-EC 5
HEATING (°C)	15/25				
COOLING (°C)	18/28				

	EXTERNAL AIR				
	HRU-EC 1	HRU-EC 2	HRU-EC 3	HRU-EC 4	HRU-EC 5
HEATING (°C)	-20/20				
COOLING (°C)	15/40				

STANDARD SIPHON (mm)

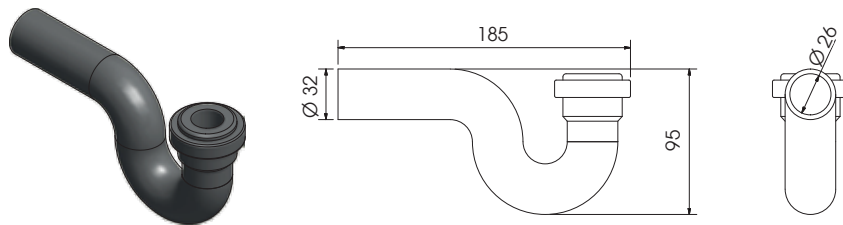

VEÉHÁHÁG II €

WESTERNTM
AIRCONDITIONING